

The software module MDPP-32-QDC provides the functionality of a fast charge integrating ADC , a Zero-Crossing detector+TDC and a pulse shape discrimination unit. It also works with short pulses of plastic scintillators and provides neutron/gamma pulse shape discrimination with liquid scintillators

MDPP-32 with QDC software module:

- **Gain-polarity jumpers**
determine: termination, polarity, input range and input configuration (differential / unipolar).
Special QDC jumpers available to get best amplitude resolution for plastic scintillators.
- **Low noise variable gain input amplifiers.**
Input signals for maximum range (highest spectrum channel)
Plastic scintillators pulse width 5ns (QDC jumpers 2V):
200mV to 5V (20pC to 500pC)
LYSO, Pulse width 30ns (any input jumper possible)
15mV to 3V (10pC to 1.5nC) (other jumpers on request)
- **Timing resolution**
down to 80ps channel to channel resolution,
TF integration / differentiation time down to 15ns
- **Pulse shape discrimination**
delivers two amplitudes: one is the standard integrated pulse amplitude (integration time 25ns to 6.4us), the second is a short integration of the rising edge of pulse. Integration as short as 12.5 ns to 1600 ns. This is fast enough to give good neutron / gamma separation for liquid scintillators
Also works for Stilbene, CLYC, CsI.
- **AC-coupled and baseline restored**
Offsets of the input signals have no effect. Even at highest rates, the amplitude keeps stable.
- **Dead time / rate capability**
Channel dead time is 400ns, (integration time up to 300ns included). For longer integration time dead time is integration time + 100ns.
- **Two high resolution monitor outputs**
for monitoring input signals and integrals of signals.
- **Two high resolution trigger inputs**
24 ps resolution, start window, add time stamp
- **One high resolution trigger output** (1.5 ns resolution)
- **Installation and update via USB**

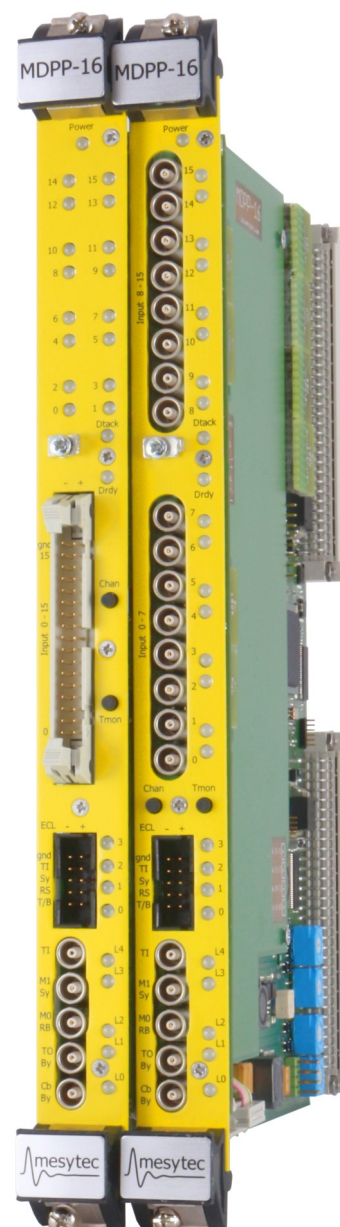

Software module: "QDC"

Delivers timing and amplitude and pulse shape analysis for signals from fast charge amplifying Detectors. For Example Photo multipliers, GEM, Channel plate..

Replaces Fast amplifier, CFD, QDC, TDC.

The following picture shows a schematic representation of the software:

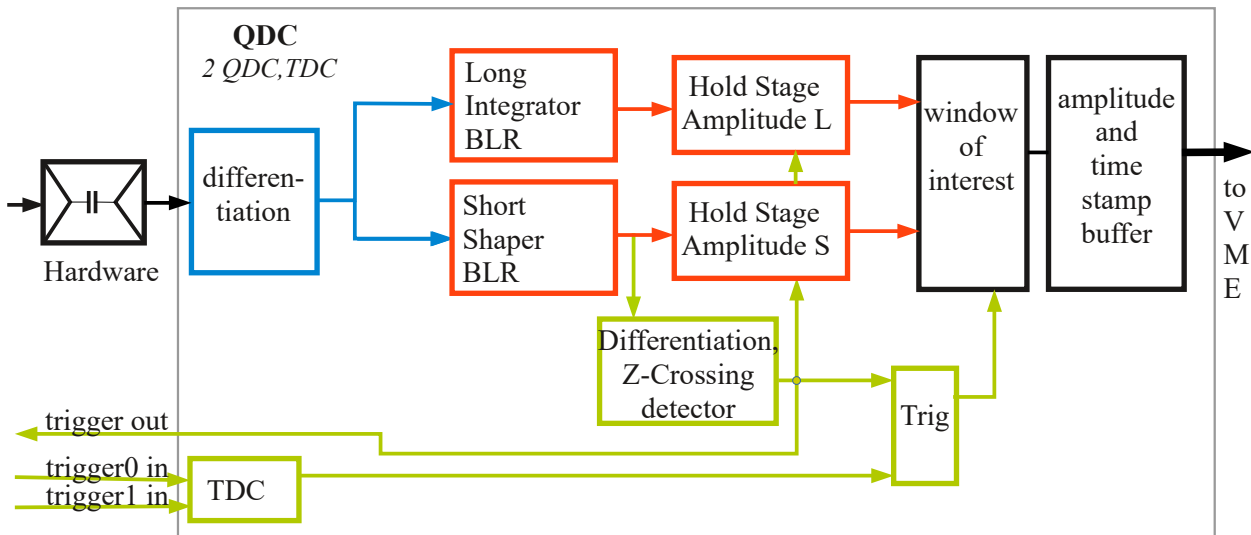

The signal is amplified filtered digitized. Then it is split into two branches: short integration and long integration.

In the "short integration" branch the signal is differentiated with a time constant down to 12.5ns, followed by an integrator. This allows to extract a very short time interval at the beginning of the pulse, which even allows to perform pulse shape discrimination with liquid scintillators. The short shaped path is also used for timing. The short pulse is discriminated to get an amplitude independent zero crossing signal. This one is used to calculate the timing.

The "long integration" path is the QDC-(Charge to digital converter) part of the processing software. Usually the full input pulse is integrated here. Integration times of 25 ns to 1600 ns are possible. As the input is AC-coupled a baseline restorer is required, to preserve a stable pulse amplitude at very high rates. The integrated signal is sampled at a well defined time, determined by the timing branch.

Then the two amplitude and timing values are fil-

tered by a **window of interest** and stored in a **buffer**.

Short data:

- Amplitude resolution of up to 4 k (12 bit)
- Trigger to channel time resolution of **60 ps rms**, uniform at any delay.
- Channel to channel time resolution of **60 ps rms**, uniform at any delay.
- Trigger input with 24 ps timing resolution
- Can be operated self triggered or externally triggered
- Outputs internal raw trigger with 1.5 ns time resolution

As easy to operate as all mesytec modules and fully data compatible.

Only 8 parameters have to be set:

In Hardware:

Polarity of the signal,
set Jumper to correct position

Register Settings

Signal properties:

1. signal width [ns]
2. maximum signal amplitude [mV]

Analysis property

3. required long integration
4. required short integration
5. threshold

Hardware Property:

Gain jumper sensitivity [mV]
QDC-Gainjumper used ?

Output Data

Amplitude:

channel 0..31 Amplitude Long int. (16 bit)
channel 64..95 Amplitude Short int. (16 bit)

Timing: Difference to window start:

channel 32 to 63 channel time difference (16bit)
Chan 96,97 Trigger input 0,1 time diff. (16 bit)

Example: The following diagram shows the charge pulse as it is produced by a liquid scintillator when detecting a neutron interaction.

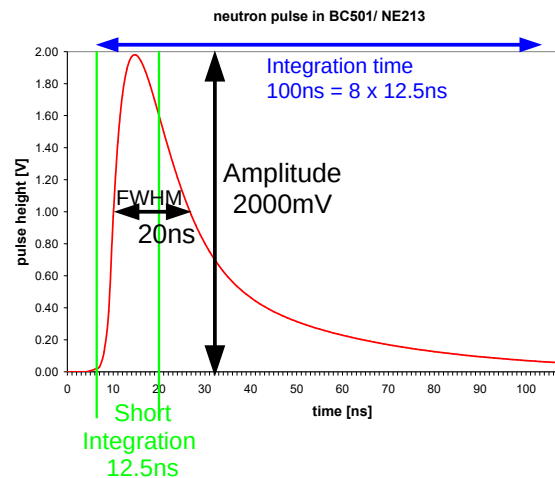

The initialization data for MDPP-32-QDC are:

Signal_width = 20
Input_Amplitude = 2000
Jumper_range = 3000 // for 3V-Jumper
QDC_Jumper = 0 // 0 = standard jumper
Integration_long = 8
Integration_short = 1
threshold0 0x200 // = 1/128 of full range 0xFFFF

For direct charge signals from PMTs connected to CsI crystals, a signal width of 600ns, short integration of 400ns (= 32 clocks) and long integration of 2.0us to 4.0us (150 to 300 clocks) performs best.

Monitor outputs

(Lemo 2 = mon 0, and Lemo 3 = mon 1)

Switching on the monitor: press pus button "chan", then select a wave form with "Tmon" button. The button "chan" allows to switch through the individual channels.

Wave forms:
Tmon 0,

Green: mon0, signal before ADC,
Magenta: mon1, differentiated input signal



Tmon0, green=inp.,mag.=differentiated

Tmon 2 :

Green: mon0, baseline from BLR, multiplied x8.

Magenta: mon 1, Long integration signal.

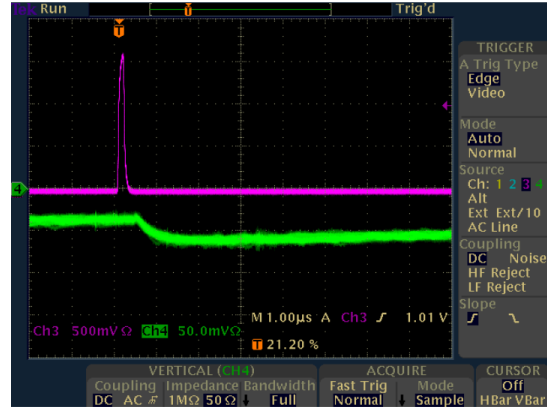

Tmon2, green=Baseline, mag.=Longint

Tmon 3: Check noise

Green: mon 0, CFD delayed subtracted signal.
Zero crossing triggers timing (delayed compared to mon1 signal).

Magenta: mon 1,timing filter signal.

Tmon 1:

Green: mon 0, short integration signal. The first positive maximum is converted.

Magenta: mon 1, long integrated signal.

The flicker mark shows the sampling time.



Tmon1, green=Shortint; mag.=Longint

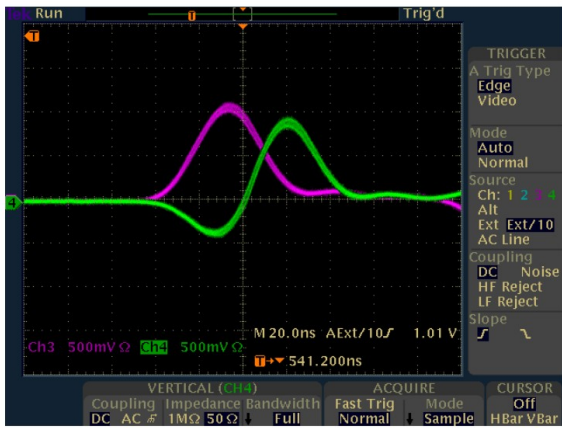

Tmon3, green=Z-cross, mag.=TF-out

Measurement done with MDPP-16 QDC software.
(MDPP-32 behaves very similar.)

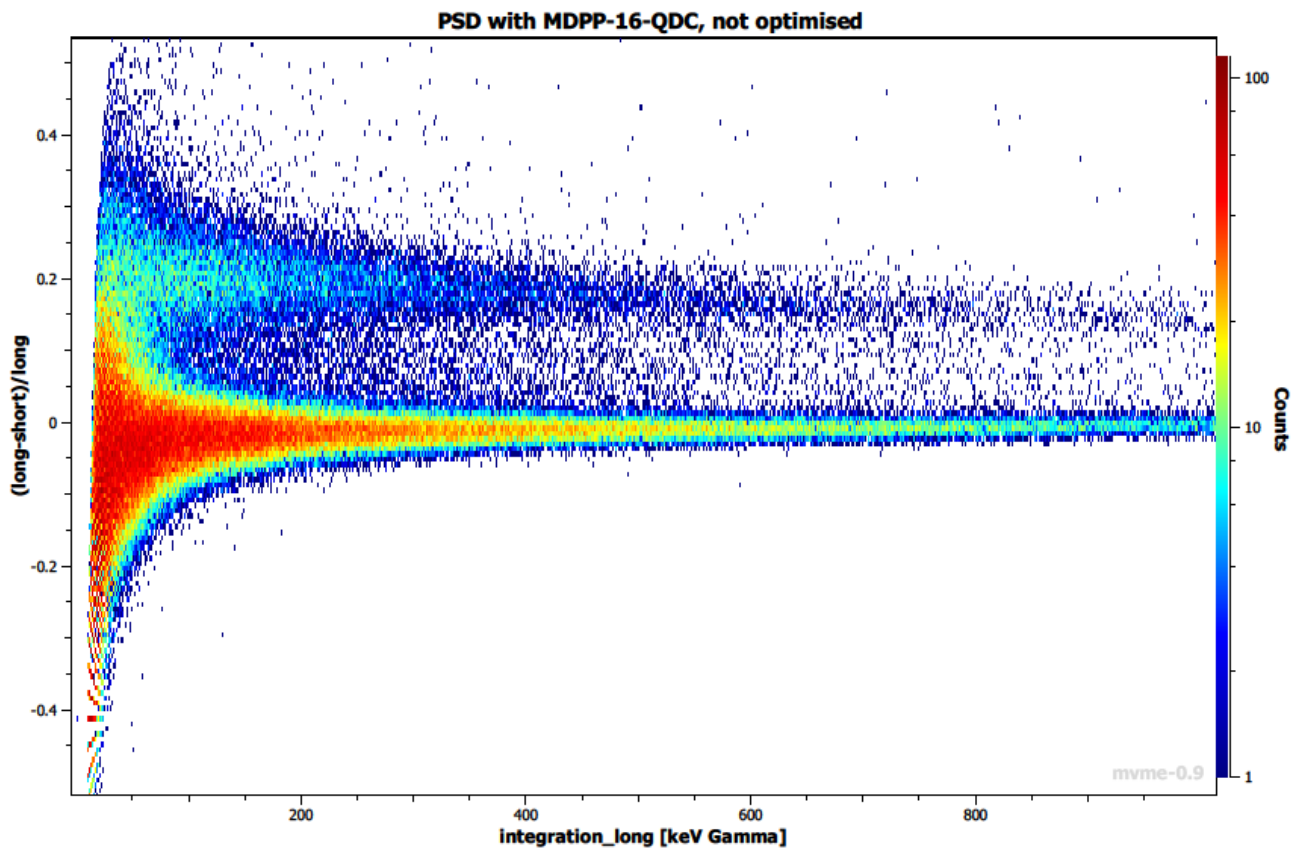

MDPP-32 register set, QDC Firmware.
Only registers which are different to SCP software modules are listed.

Data FIFO, read data at address 0x0000 (access R/W D32, 64)

only even numbers of 32 bit-words will be transmitted. In case of odd number of data words, the last word will be a fill word (= 0).

 FIFO size: $48\text{ k} - 512 = 48640$ words with 32 bit length

Header (4 byte)

2 header signature	2 subheader	4	8 module id	3 TDC_resolution → 0x6042	3 ADC_resolution → 0x6046	10 number of following data words, including EOE
b01	b00	xxxx	module id	bxxx	bxxx	number of 32 bit data words

Data (4 byte) DATA event

2 data-sig	2	4	1	7	16
b00	01	xxxx	overflow	channel number 0..31	ADC value long integration

Data (4 byte) DATA event

2 data-sig	2	4	1	7	16
b00	01	xxxx	overflow	channel number 94..125	ADC value short integration

Data (4 byte) DATA event

2 data-sig	2	5	7	16
b00	01	xxxxx	channel number 32..63	TDC time difference

Data (4 byte) DATA event

2 data-sig	2	5	7	16
b00	01	xxxxx	channel number 64..65	Trigger time difference External trigger input T0, T1

Data (4 byte) Extended time stamp

2 data-sig	2	12	16
b00	10	xxxx xxxx xxxx	16 high bits of time stamp

Data (4 byte), fill dummy (to fill MBLT64 word at odd data number)

2 data-sig	30
b00	0

End of Event mark (4 byte)

2	30
b11	event counter / time stamp

trigger counter/ 30 bit trigger counter or time stamp information, depending on register
time stamp 0x6038 “marking type”: 0 = event counter, 1 = time stamp

Registers

	operation mode				
0x6044	output_format	2	RW	3	0 = time and long integral 1 = long_integral only (QDC-mode) 2 = time only (TDC mode) 3= long_integral, short_integral and time
0x6046 ⁽¹⁾	adc_resolution ⁽¹⁾			4	0 = 64k for new setups Always use 64k setting ! 1 = 32k 2 = 16k 3 = 8k 4 = 4k (default)

Channel addressing (select channel which are set)

0x6100	select_chan_quadruples	4	RW	8	channel to be modified: 0..7 channel quads; 0 = chan 0,1,2,3 1 = chan 4,5,6,7 8 = all channels (set to common values)
--------	------------------------	---	----	---	---

Channel settings for Quads of channels,

***** After writing a register in this page, 20 us wait time is required *******

Address	Parameter				
0x6110	Signal_width	10	RW	16	[FWHM, ns],
0x6112	Input_Amplitude	16	RW	1024	[mV], input amplitude 0 to peak in mV max value is the jumper range
0x6114	Jumper_range	16	RW	3072	[mV], Range printed on jumper top
0x6116	QDC_Jumper	1	RW	0	1=yes, 0=no
0x6118	Integration_long	9	RW	16	[12.5 ns], 2..506 ⁽¹⁾ in clock steps of 12.5ns
0x611A	Integration_short	7	RW	2	[12.5 ns], 1..127 ⁽¹⁾ in clock steps of 12.5ns must be < than long integration
0x611C	threshold0	15	RW	0xFF	1...0xFFFF; example: 0.8% = 0x200;
0x611E	threshold1	15	RW	0xFF	
0x6120	threshold2	15	RW	0xFF	
0x6122	threshold3	15	RW	0xFF	
0x612A	long_gain_correction	12	RW	1024	256: divide by 4, 4096 multiply by 4, 1024 neutral;
0x612E	short_gain_correction	12	RW	1024	

Note(1), Since March 2021

How to set channel parameters

Signal_width This is the width of the input pulse at half the peak amplitude in ns. The pulse must be measured with a **terminated** oscilloscope. Do not measure at the monitor output of MDPP-32 ! it does not have the band width to properly measure the pulse width;

Input_amplitude: This is the amplitude of the input pulse measured from base line to peak in mV. Offsets of the signal have no effect. The pulse must be measured with a terminated oscilloscope. Do not measure at the monitor output of MDPP-32 ! it does not have the band width to properly measure the pulse width;

Jumper range: The value is printed on the jumper. multiply the value by 1000 to get the mV unit.

QDC_Jumper: set 1 if you used a QDC-Jumper;
Those jumpers are obsolete. MDPP-32 hardware has been changed to give best results with standard jumpers.

Integration_long: is the integration time to get the full charge of the input pulse.
It is specified in multiples of internal clocks, so 12.5ns. Allowed range is 2 (25ns) to 127 (1.6us)

Integration_short: is the integration time to get the first fast part of the input pulse.
It is specified in multiples of internal clocks, so 12.5ns. Allowed range is 1 (12.5ns) to 31 (387ns)
It must be smaller than the long integration time.

Threshold 0 to 3: The threshold parameter can be set separately for the four addressed channels.
Full range is 64k (65535) = 0xFFFF; So a 1% of full range threshold is $65535/100 = 655$;

Gain_corrections: The internal gains and hardware gain are calculated based on the signal width and amplitude. This should give a quite good start value. Details of the signals will have an effect on the real amplitude. So there are 2 scaling factors to correct the gains. The default of 1024 is the neutral setting, a lower value decreases the amplitude in a spectrum, a higher one increases it. It is possible to decrease the gain by a factor of 4 (->256), or increase it by a factor of 4 (-> 4095).