



Register your device

Register your device to your **MyCAEN+** account and get access to our customer services, such as notification for new firmware or software upgrade, tracking service procedures or open a ticket for assistance. **MyCAEN+** accounts have a dedicated support service for their registered products. A set of basic information can be shared with the operator, speeding up the troubleshooting process and improving the efficiency of the support interactions.

MyCAEN+ dashboard is designed to offer you a direct access to all our after sales services. Registration is totally free, to create an account go to <https://www.caen.it/become-mycaenplus-user> and fill the registration form with your data.



1

create a MyCAEN+ account

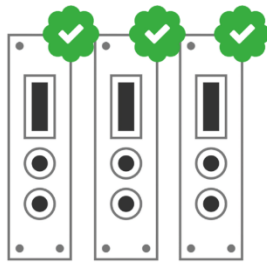

2

register your devices

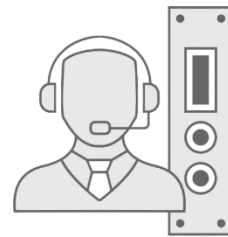

3

get support and more!



<https://www.caen.it/become-mycaenplus-user/>

Technical Information Manual

Revision n. 1
27 September 2002

MOD. V560 series

*16 CHANNEL
SCALERS*

CAEN will repair or replace any product within the guarantee period if the Guarantor declares that the product is defective due to workmanship or materials and has not been caused by mishandling, negligence on behalf of the User, accident or any abnormal conditions or operations.

CAEN declines all responsibility for damages or injuries caused by an improper use of the Modules due to negligence on behalf of the User. It is strongly recommended to read thoroughly the CAEN User's Manual before any kind of operation.



CAEN reserves the right to change partially or entirely the contents of this Manual at any time and without giving any notice.

TABLE OF CONTENTS

TABLE OF CONTENTS	3
1. DESCRIPTION	4
1.1. FUNCTIONAL DESCRIPTION	4
2. SPECIFICATIONS.....	6
2.1. PACKAGING	6
2.2. EXTERNAL COMPONENTS.....	6
2.3. INTERNAL COMPONENTS.....	7
2.4. POWER REQUIREMENTS	7
2.5. CHARACTERISTICS OF THE SIGNALS.....	7
3. OPERATING MODES	10
3.1. COUNTING SCALES	10
3.2. INTERRUPT GENERATION	11
3.3. FRONT PANEL SIGNALS.....	12
3.4. SCALE INHIBIT	13
3.5. SCALE CLEAR.....	13
3.6. CHANNELS TEST.....	13
3.7. MODULE CONFIGURATION.....	14
3.8. V560 POWER SELECTION	14
4. VME INTERFACE.....	16
4.1. ADDRESSING CAPABILITY	16
4.2. DATA TRANSFER CAPABILITY.....	16
4.3. MODULE IDENTIFIER WORDS	19
4.4. SCALE STATUS REGISTER	19
4.5. SCALE INCREMENT	20
4.6. VETO SET/RESET	20
4.7. CLEAR SCALES	20
4.8. COUNTERS	21
4.9. REQUEST REGISTER.....	22
4.10. CLEAR VME INTERRUPT	22
4.11. ENABLE/DISABLE VME INTERRUPT.....	22
4.12. INTERRUPT LEVEL & VETO REGISTER	23
4.13. INTERRUPT VECTOR REGISTER	23
5. MOD. V560 INTERRUPTER	24
5.1. INTERRUPTER CAPABILITY	24
5.2. INTERRUPT LEVEL.....	24
5.3. INTERRUPT STATUS/ID	24
5.4. INTERRUPT REQUEST RELEASE	24
5.5. ENABLE/DISABLE INTERRUPT GENERATION	24
5.6. INTERRUPT SEQUENCE.....	24
6. REFERENCES	26

1. DESCRIPTION

1.1. FUNCTIONAL DESCRIPTION

The model V560 is a 1-unit wide VME module provided with 16 independent 32-bit counting channels operating at the guaranteed input frequency of 100 MHz.

The channels are grouped in 8 section of two channels; for each section it is possible:

- to enable/disable the channels interrupt generation;
- to connect (via internal changeover switches) the two channels to obtain a single 64 bit scale.

The module houses a VME RORA INTERRUPTER[1] that generates a VME interrupt (if enabled) whenever the most significant bit of a scale becomes true

The module operation is fully controlled through VME. Some operations can be also performed by three external NIM signals (indicated on the front panel connectors with "VETO", "CLEAR", "TEST"):

- VETO: (INHIBIT) an input signal sent through this connector disables the counting.
- CLEAR: (FAST CLEAR) an input signal present on this connector resets all the channels (it is possible to perform the same operation by pressing the "MAN CLR" push-button located on the front panel).
- TEST: if the module is configured with 16 independent channels, a pulse sent through this connector increases all the channels.

These inputs are high impedance and each one is provided with two bridge connectors for daisy chaining.

The module V560 is an A24/A32 D16/D32 VME slave; its Base address is fixed by 6 internal rotary switches. A front panel LED (DTACK) lights up each time the module generates the VME signal DTACK.

The Model uses the P1 and P2 connector of VME and optionally the auxiliary connector for the CERN V430[2] VMEbus crate (Jaux Dataway).

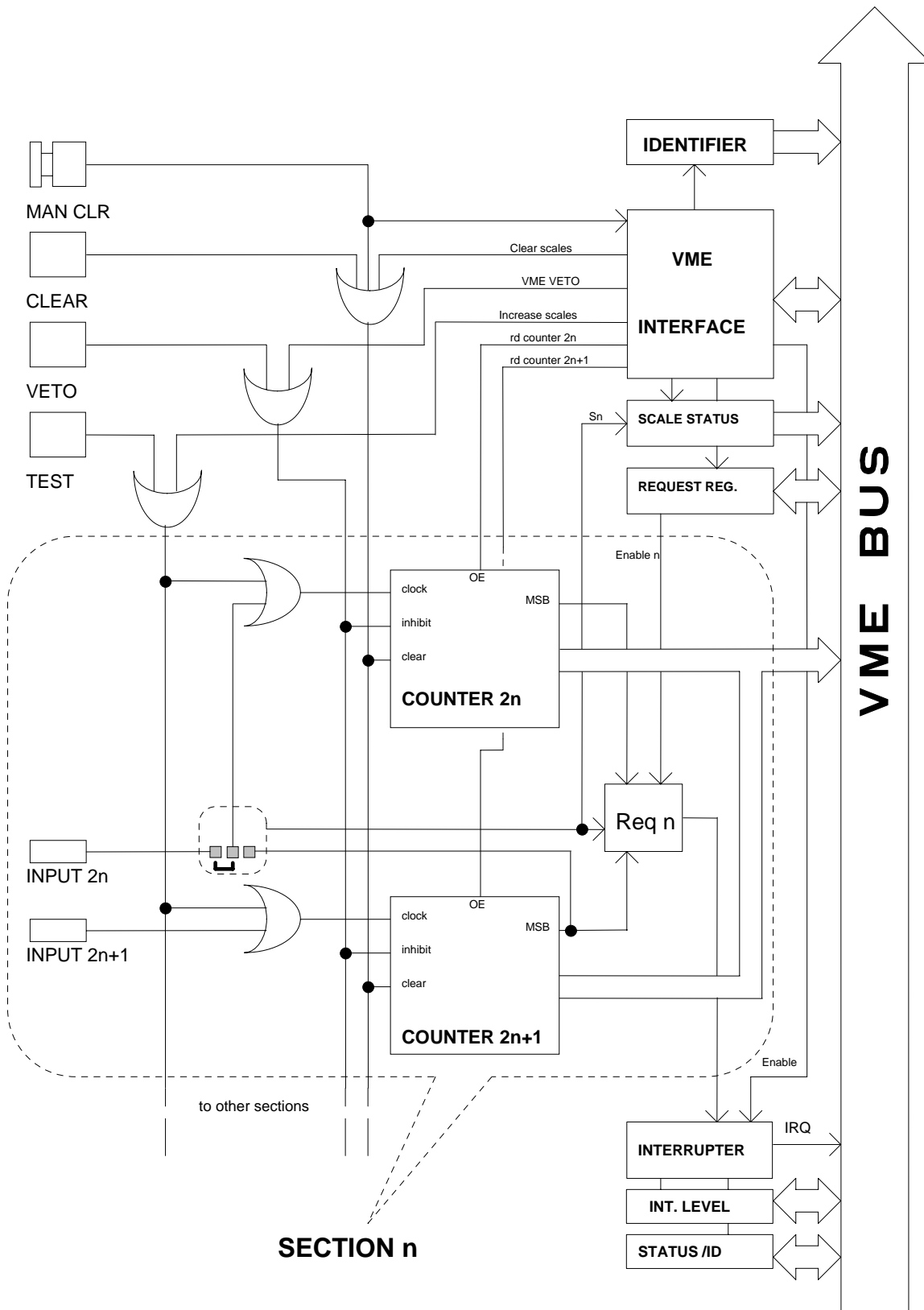

Fig. 1.1: Mod. V560 block diagram

2. SPECIFICATIONS

2.1. PACKAGING

1-unit wide VME unit. Height: 6U.

2.2. EXTERNAL COMPONENTS

CONNECTORS

- No.2, "IN 0..7", "IN 8..15", 16 pin lead flat cable connector, 110 Ω impedance; for the 16 input channels.

- No.2, "TEST", LEMO 00 type, 50 Ω impedance; two bridge connectors (for daisy chaining) for the TEST input signal.

- No.2, "CLEAR", LEMO 00 type, 50 Ω impedance; two bridge connectors (for daisy chaining) for the CLEAR input signal .

- No.2, "VETO", LEMO 00 type, 50 Ω impedance; two bridge connectors (for daisy chaining) for the VETO input signal.

LEDs

- No.1, "DTACK", green, VME Selected; it lights up during a VME access.

SWITCHES

- No.1, "MAN CLR", manual clear push-button; by pushing this button:

- all the counting scales are cleared;
- the VME interrupt request (if asserted) is removed;
- the VME interrupt generation are disabled;
- the VME VETO is cleared.

2.3. INTERNAL COMPONENTS

(refer to fig.2.2 and Appendix C - components location)

JUMPERS

- No.1, jumper "JP2"; for the -5 V power selection.

SWITCHES

- No.8, changeover switches (group "JP3..JP10"). For connect the two channels of each section to obtain a single 64 bit scale.

- No.6, rotary switches for the module VME Base address selection.

2.4. POWER REQUIREMENTS

Crate Type	+ 5 V	- 12 V	- 5 V
Standard	2 A	160 mA	==
Type V430	2 A	==	160 mA

2.5. CHARACTERISTICS OF THE SIGNALS

- INPUT CHANNELS: std. differential ECL level, 110 Ω impedance;
max. frequency:100 MHz; min. width 5 ns;
min. time interval between two pulses: 5 ns.
- VETO(*): std. NIM level, high impedance;
min. width 50 ns;
it must precede the input channel signal by at least 35ns.
- CLEAR(*): std. NIM level, high impedance; min. width: 60 ns.
- TEST(*): std. NIM level, high impedance; max. frequency: 50 MHz;
min. width: 10 ns.

(*) These inputs are high impedance and each one is provided with two bridge connectors for daisy chaining. Note that the high impedance makes these inputs sensitive to noise, so the chains have to be terminated on 50 Ω on the last module; the same is needed also if one module only is used, whose inputs have thus to be properly matched.

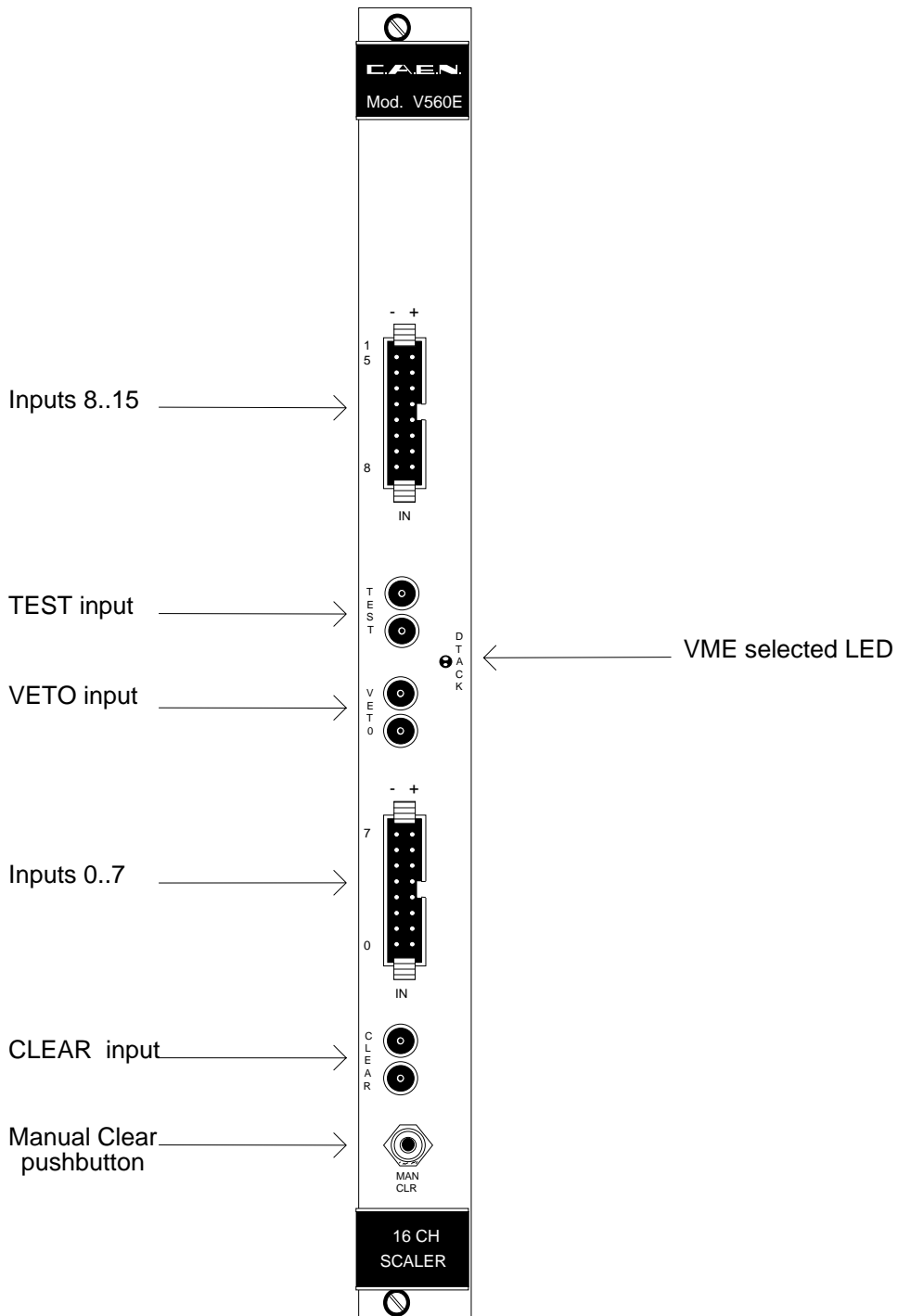

Fig. 2.1: Mod. V560 Front panel

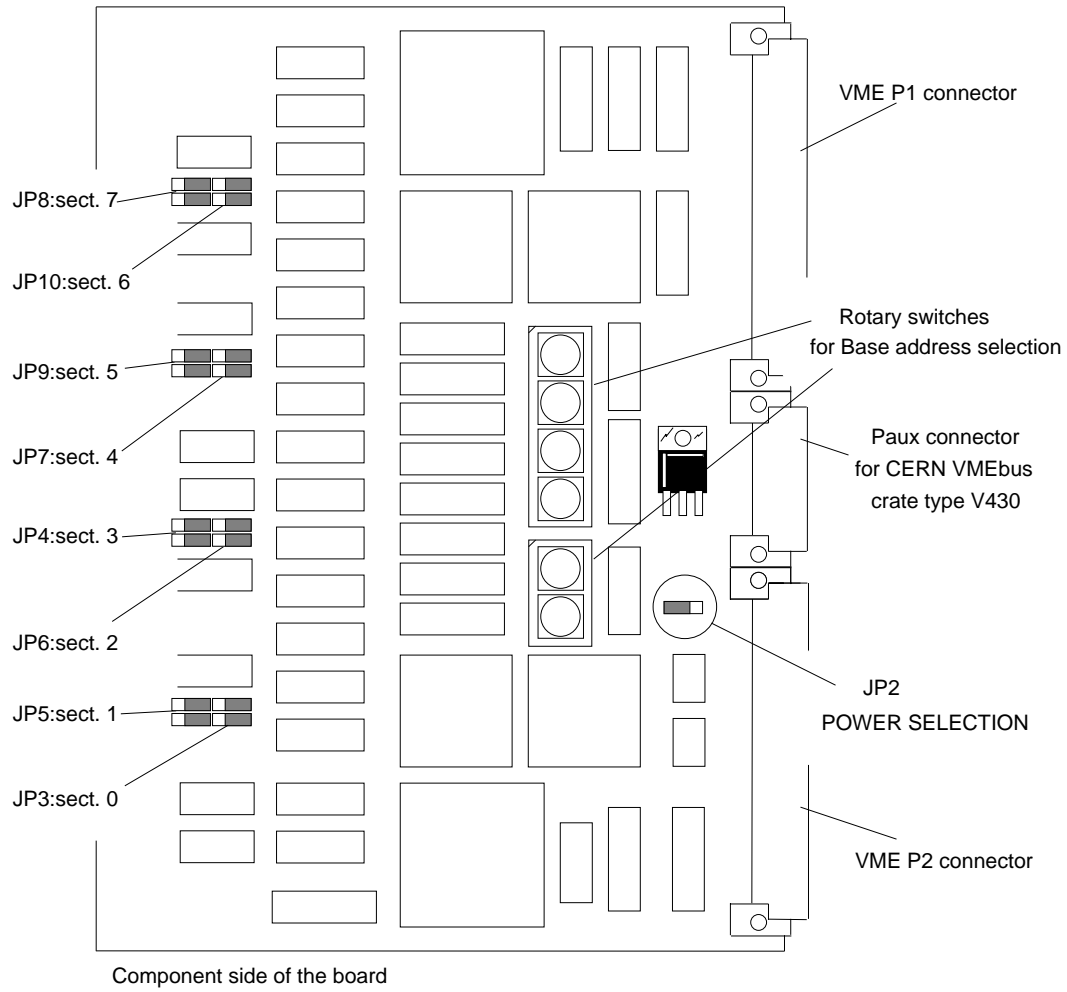

Fig. 2.2: Mod. V560 components locations

3. OPERATING MODES

3.1. COUNTING SCALES

The module V560 houses 16 independent 32-bit channels that are grouped in 8 sections of two channels. For each section the two channels can be cascaded by internal changeover switches in order to obtain a single 64-bit scale.

The picture on the following page shows the changeover switches' location and position for the different operating modes.

For each section, the corresponding changeover switch allows the connection of the even channel to the following one, or to the corresponding input:

If the section n is configured as two 32-bit scales:

- the clock of the channel $2n$ is the external input $2n$;
- the clock of the channel $2n+1$ is the external input $2n+1$.

If the section n is configured as a single 64-bit scales,

- the clock of the channel $2n$ is the 32th bit of the channel $2n+1$;
- the clock of the channel $2n+1$ is the external input $2n + 1$.

The 64-bit scale obtained has the following characteristics:

- the clock input of the 64-bit scale is the external input $2n + 1$
- LSB of the scale value = channel $2n+1$ counting value
- MSB of the scale value = channel $2n$ counting value

It is possible to read the status of the changeover switches via VME (see § 4.4). The table 3.1 summarizes the characteristics of the eight 64-bit scales:

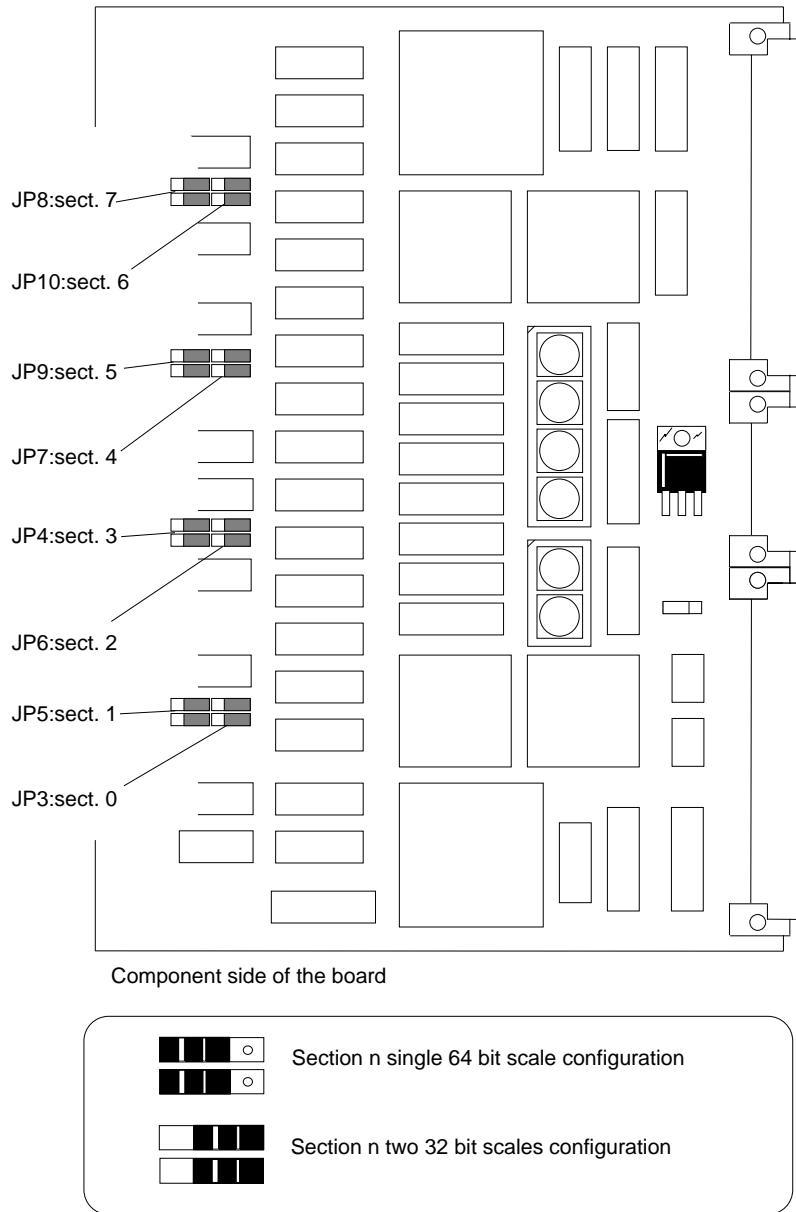

Fig. 3.1: Mod. V560 jumper settings

Section number	64-bit scale		External Input of the scale	Changeover sw. location
	MSB	LSB		
0	ch.0	ch.1	input 1	JP3
1	ch.2	ch.3	input 3	JP5
2	ch.4	ch.5	input 5	JP6
3	ch.6	ch.7	input 7	JP4
4	ch.8	ch.9	input 9	JP7
5	ch.10	ch.11	input 11	JP9
6	ch.12	ch.13	input 13	JP10
7	ch.14	ch.15	input 15	JP8

Table 3.1 Characteristics of the eighth 64-bit scales of Mod.V560

3.2. INTERRUPT GENERATION

The operations of the V560 VME INTERRUPTER are fully software programmable; via VME it is possible:

- to enable /disable the VME interrupt generation;
- to set the VME interrupt level;
- to program the VME interrupt vector (STATUS/ID).

Moreover for each section it is possible to enable/disable the scales interrupt generation (see § 4.9).

If the VME INTERRUPTER is enabled, it generates a VME interrupt whenever the most significant bit of an enabled scale becomes true:

- If the section is configured with two independent 32-bit scales, it generates an interrupt when the 32th of one of the two channels becomes true.
- If the section is configured with one 64-bit scale, it generates an interrupt when the 64th bit of the scale becomes true (i.e., the 32th bit of the even channel).

3.3. FRONT PANEL SIGNALS

Some operations can be performed by three external NIM signals (indicated on the front panel connectors with "VETO", "CLEAR", "TEST"):

- VETO: (INHIBIT) an input signal sent through this connector disables the counting.
- CLEAR: (FAST CLEAR) an input signal present on this connector resets all the channels (it is possible to perform the same operation by pressing the "MAN CLR" push-button located on the front panel).
- TEST: if the module is configured with 16 independent channels, a pulse sent through this connector increases all the channels.

These inputs are high impedance and each one is provided with two bridge connectors for daisy chaining.

Note that the high impedance makes these inputs sensitive to noise, so the chain has to be terminated on 50Ω on the last module; the same is needed also if one module only is used, whose inputs have thus to be properly matched.

3.4. SCALE INHIBIT

It is possible to inhibit the scales count in this way:

- by sending a NIM signal through one of the two "VETO" connectors located on the front panel.
- by setting the VME VETO (access to the address Base + %52; see § 4.6).

The VME VETO is cleared:

- by pushing the front panel push-button "MAN CLR";
- by resetting the VME VETO (access to the address Base + %54; see § 4.6).

3.5. SCALE CLEAR

All the scales are cleared in the following cases:

- by sending a NIM signal through one of the two "CLEAR" connectors located on the front panel;
- by pushing the front panel push-button "MAN CLR";
- by accessing via VME the address Base + %50 (Scale Clear see § 4.7);
- by generating the VME signal SYSRES.

3.6. CHANNELS TEST

If the module is configured with 16 independent channels it is possible to increment all channels:

- by sending a NIM pulse through one of the two "TEST" connectors located on the front panel.
- by accessing via VME the address Base + % 56 (Scale Increase see § 4.5).

3.7. MODULE CONFIGURATION

The module is supplied by CAEN with the internal jumpers as shown in Figure 2.2. In this arrangement each section is configured with two independent 32bit counting scales

At power-on:

- all the scales are cleared;
- VME VETO is cleared;
- VME interrupt is disabled.

3.8. V560 POWER SELECTION

The model V560 can be used in the standard VME crates or in the CERN VMEbus crates type V430 [2].

The module needs -5.2 V power for the ECL input stages; a jumper (JP2) is used to select the crate type:

Standard crates:

The - 5.2 V power is generated on board from the standard voltage -12V provided on the VME backplane.

JP2 must be located in the "- 5 EXT" position.

CERN VMEbus crate Type V430:

The - 5.2 V power is provided from a not VME standard voltage bus located on the backplane of the crate type V430.

This backplane (VMEbus BIN type V431, see [2] § 2) is a monolithic printed circuit board that provides the VMEbus standard J1 and J2 dataway and a third dataway (named "Jaux") which is not foreseen by the VME standard.

The Jaux dataway provides some signals, the -5.2 V and -2 V requested by fast ECL logic front end modules and the +15 V and -15 V rails. This dataway is situated in the free space available between J1 and J2.

JP2 must be located in the "- 5 INT " position.

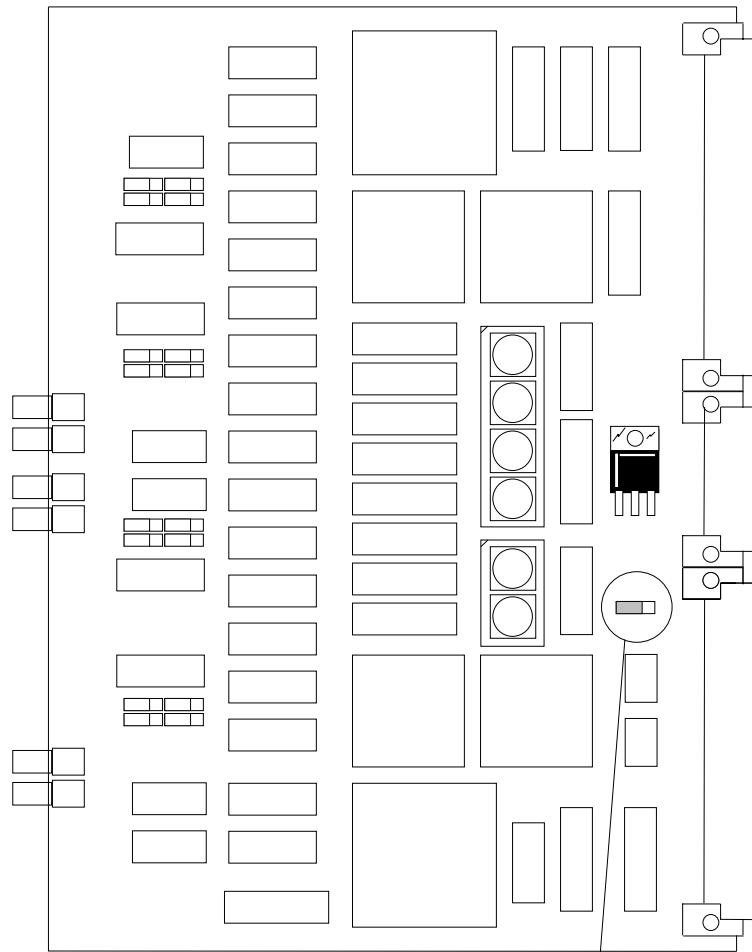

Component side of the board

JP2 (POWER SELECTION) settings:

- VMEbus crate type V430 position (-I -5 INT)
- Standard crates position (-E -5 EXT)

Fig. 3.1: Mod. V560 JP2 settings

4. VME INTERFACE

4.1. ADDRESSING CAPABILITY

The module works in A32/A24 mode. This means that the module address must be specified in a field of 32 or 24 bits. The Address Modifiers code recognized by the module are:

AM=%39:	standard user data access
AM=%3D:	standard supervisor data access
AM=%09:	extended user data access
AM=%0D:	extended supervisor data access

The module's Base Address is fixed by 6 internal rotary switches housed on two piggy-back boards plugged into the main printed circuit board (see Fig. 4.1).

The Base Address can be selected in the range:

% 00 0000 <-> % FF FF00	A24 mode
% 0000 0000 <->% FFFF FF00	A32 mode

The Base Address reserves in this way a page of 256 bytes for the module. The address map of the page is shown in table 4.1.

4.2. DATA TRANSFER CAPABILITY

The module has the following data transfer capability:

- the internal registers are accessible in D16 mode;
- the counters are accessible in D16/D32 mode.

This means that the counters can be read either by Word or Long Word instructions, while the register can be read by Word instructions only.

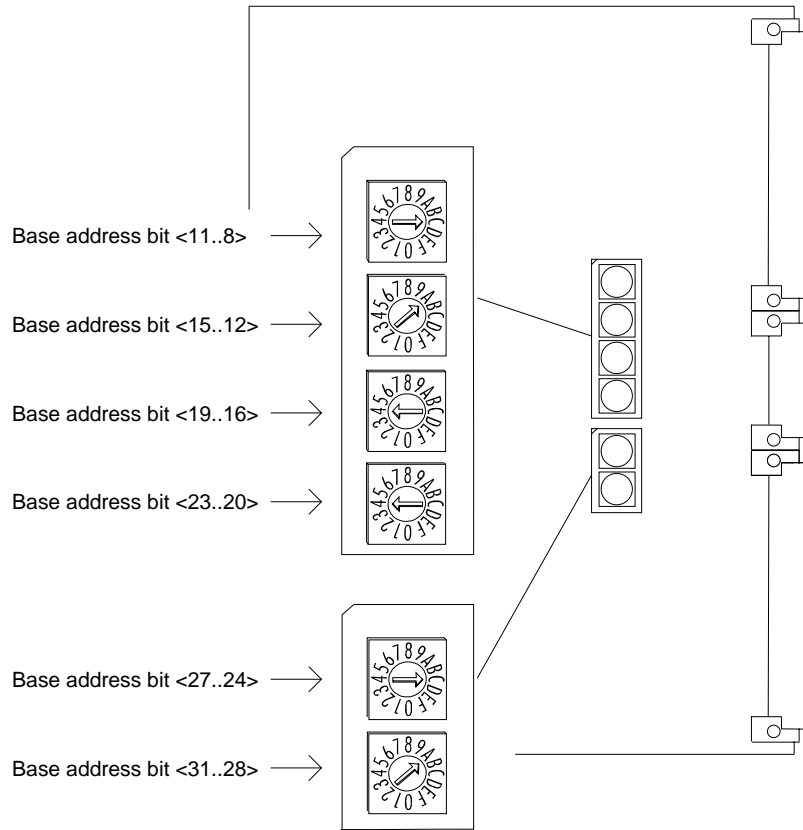

Fig. 4.1: Mod. V560 Base address setting.

Table 4.1: Address Map for the Mod. V 560

ADDRESS	REGISTER/CONTENT	TYPE
Base + %FE Base + %FC Base + %FA	Version & Series Manufacturer & Module Type Fixed code	read only read only read only
Base + %5A...Base + %F8	Not used	
Base + %58 Base + %56 Base + %54 Base + %52 Base + %50 Base + %4C Base + %48 Base + %44 Base + %40 Base + %3C Base + %38 Base + %34 Base + %30 Base + %2C Base + %28 Base + %24 Base + %20 Base + %1C Base + %18 Base + %14 Base + %10	Scale Status register Scale Increase VME VETO reset VME VETO set Scale clear Counter 15 Counter 14 Counter 13 Counter 12 Counter 11 Counter 10 Counter 9 Counter 8 Counter 7 Counter 6 Counter 5 Counter 4 Counter 3 Counter 2 Counter 1 Counter 0	read only read/write read/write read/write read/write read only read only read only read only read only read only read only read only read only read only read only read only read only read only read only read only
Base + %0E Base + %0C Base + %0A Base + %08 Base + %06 Base + %04	Request register Clear VME Interrupt Disable VME Interrupt Enable VME Interrupt Interrupt Level & VETO register Interrupt Vector register	read/write read/write read/write read/write read/write read/write
Base + %02 Base + %00	Not used Not used	

4.3. MODULE IDENTIFIER WORDS

(Base address + %FA ,+%FC, +%FE read only)

The Three words located at the highest address on the page are used to identify the module as shown in figure 4.1:

15	14	13	12	11	10	9	8	7	6	5	4	3	2	1	0	Address
Version				Module's serial number												Base + % FE
Manufacturer number						Module type									Base + % FC	
% F A Fixed code						% F 5 Fixed code									Base + % FA	

Fig. 4.2: Module Identifier words

At the address Base + % FA the two particular bytes allow the automatic localization of the module.

For the Mod. V560 the word at address Base + % FC has the following configuration:

Manufacturer N°= 000010 b
 Type of module = 0000011000 b

The word located at the address Base + %FE identifies the single module through the module's serial number and any change in the hardware, (for example the use of faster logic) will be shown by the Version number.

4.4. SCALE STATUS REGISTER

(Base address + %58 read only)

This read-only register contains the scales' configuration of the module. The bits 0 to 7 indicates the status of the 8 changeover switches of the 8 sections (bits 8 to 15 are unused and are read as "one" on the VME data bus).

- bit =0 section configured with two 32-bit scales;
- bit =1 section configured as a single 64-bit scale.

The following figure shows the structure of the Scale Status register.

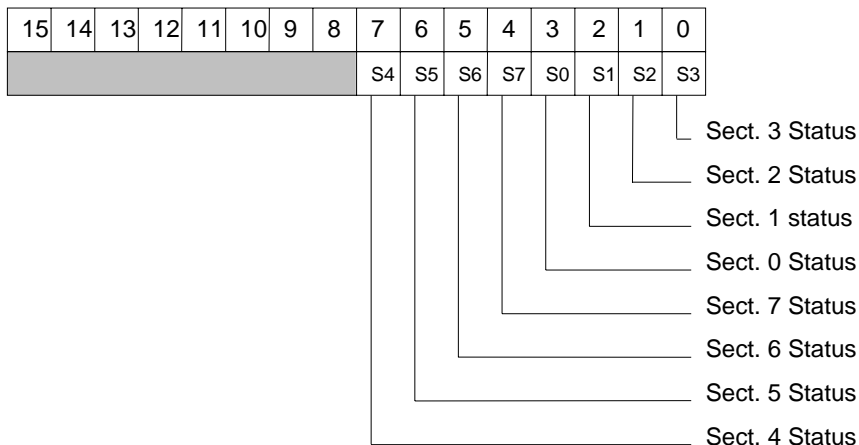

Fig. 4.3: Scale Status register

4.5. SCALE INCREMENT

(Base address + %56 r/w)

If the module is configured with 16 independent channels, a VME access (read or write) to this location increases all the channels (same as the TEST signal).

4.6. VETO SET/RESET

(Base address + %52, Base address + %54 r/w)

A VME access (read or write) to the address Base + % 52 sets the VME VETO; the scales are not able to count.

A VME access (read or write) to the address Base + % 54 clears the VME VETO; If no external VETO is present, the scales are able to count.

4.7. CLEAR SCALES

(Base address + %50 r/w)

A VME access (read or write) to this location causes the following operation:

- all the scales are cleared;
- the VME interrupt request (if asserted), is removed (RORA INTERRUPTER);
- the VME interrupt generation is disabled.

4.8. COUNTERS

(Base address + %10 ... Base address + % 4C read only)

There are sixteen 32 bit read only registers. They contain the 32 bit value of the corresponding counting channels

These registers can be read in D16/D32 mode. When the D16 mode is used (word cycles), the register content is located on the 16 bit data bus following Motorola standard, i.e., the most significant word is located at the lowest VME address. The Figs 4.3 and 4.4 show how the counter value is located on the data bus in the two different cases.

31	30	29	28	27	26	25	24	23	22	21	20	19	18	17	16	15	14	13	12	11	10	9	8	7	6	5	4	3	2	1	0	ADDRESS
C o u n t e r 0 <31..0>																Base + % 10																
C o u n t e r 1 <31..0>																Base + % 14																
C o u n t e r 2 <31..0>																Base + % 18																

Fig. 4.4: Counter value disposition on the data lines during Long Word read cycles.

15	14	13	12	11	10	9	8	7	6	5	4	3	2	1	0	ADDRESS
C o u n t e r 0 <31..16>										Base + % 10						
C o u n t e r 0 <15..0>										Base + % 12						
C o u n t e r 1 <31..16>										Base + % 14						
C o u n t e r 1 <15..0>										Base + % 16						
C o u n t e r 2 <31..16>										Base + % 18						
C o u n t e r 2 <15..0>										Base + % 1A						

Fig. 4.5: Counter value disposition on the data lines during Word read cycles.

The status of the VETO is latched whenever a counting channel is read via VME; and it is available in the Interrupt Level & VETO register (8th bit):

- VETO = 0 the module was in the inhibit state when the channel has been read;
- VETO = 1 the module was able to count when the channel has been read.

If the module was able to count, the counter value previously read has been latched "on fly" and may be not correct.

During word cycle the VETO value is latched during the access at the lowest addresses.
 During word cycle the 32 bit counter value is latched during the access at the lowest addresses.

4.9. REQUEST REGISTER

(Base address + %0E r/w)

This register allows to control the VME interrupt generation for each section.

- Request register<n> =1 section n scales are able to generate a VME interrupt
- Request register<n> =0 section n scales are not able to generate a VME interrupt

(Bits 8 to 15 are unused and are read as "one" on the VME data bus).

The following figure shows the structure of the Request register

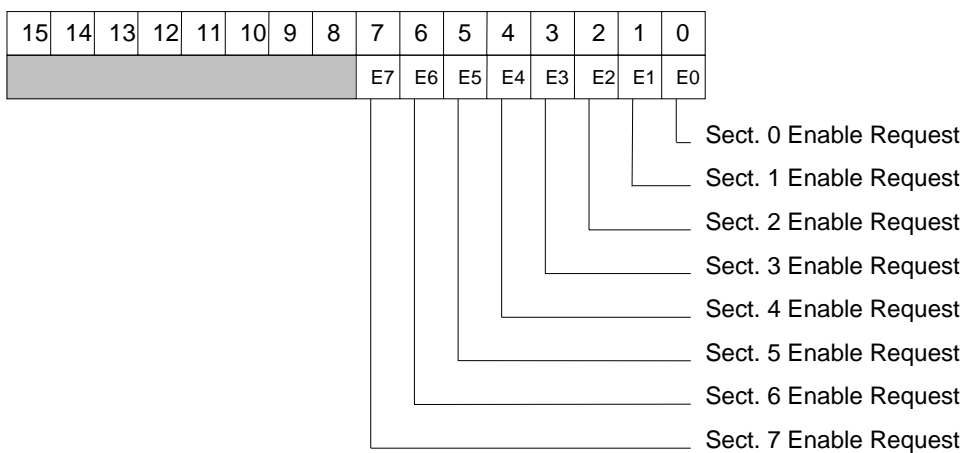

Fig. 4.6: Request register

4.10. CLEAR VME INTERRUPT

(Base address + % 0C r/w)

A VME access (read or write) to this location removes the VME interrupt request (if asserted), (RORA INTERRUPTER).

4.11. ENABLE/DISABLE VME INTERRUPT

(Base address + % 08 + % 0A r/w)

A VME access (read or write) to the address Base +% 08 enables the VME interrupt generation.

A VME access (read or write) to the address Base +% 0A disables the VME interrupt generation.

4.12. INTERRUPT LEVEL & VETO REGISTER

(Base address + %06 r/w)

This register contains the value of the interrupt level set (bit <0..2>) and the status of the VETO latched during the last read counter operation (bit<8>). Bits <7..3> and bits <15..8> are unused and are read as "one" on the VME data bus.

The status of the VETO is latched whenever a counting channel is read via VME;

- VETO = 0 the module was in the inhibit state when the channel has been read.
- VETO = 1 the module was able to count when the channel has been read.

If the module was able to count, the counter value previously read has been latched "on fly" and may be not correct.

During word cycle the VETO value is latched during the access at the lowest addresses.

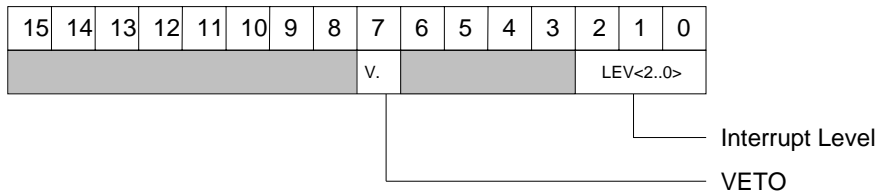

Fig. 4.7: Interrupt Level & VETO register

4.13. INTERRUPT VECTOR REGISTER

(Base address + %04 r/w)

The value stored in this register is the STATUS/ID that the V560 INTERRUPTER places on the VME data bus during the interrupt acknowledge cycle. (Bits 8 to 15 are unused and are read as "one" on the VME data bus).

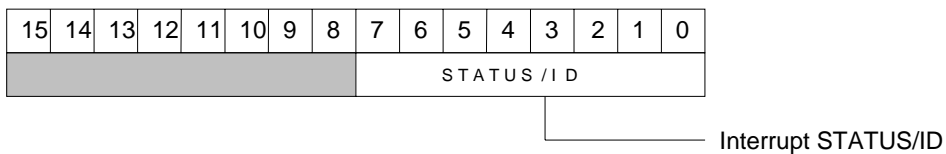

Fig. 4.8: Interrupt Vector register

5. MOD. V560 INTERRUPTER

5.1. INTERRUPTER CAPABILITY

The Mod. V560 houses a VME RORA INTERRUPTER D08(o) type. This means that:

- it responds to 8 bit, 16 bit and 32 bit interrupt acknowledge cycles providing an 8-bit STATUS/ID on the VME data lines D00..D07;
- it removes its interrupt request when some on board registers are accessed by a VME MASTER (RORA: Release On Register Access).

5.2. INTERRUPT LEVEL

The interrupt level corresponds to the value stored in the Interrupt Level & VETO register <2..0>. the register is available at the VME address Base + % 06.

5.3. INTERRUPT STATUS/ID

The interrupt STATUS/ID is 8 bit wide, and it is contained in the Interrupt Vector register<7..0> (address Base + % 04).

5.4. INTERRUPT REQUEST RELEASE

The V560 INTERRUPTER removes its interrupt request in these cases:

- by accessing the address Base + % 0C (Clear VME interrupt);
- by accessing the address Base + % 50 (Clear Scales);
- by pushing the front panel push-button "MAN CLR";
- by generating the VME signal SYSRES.

5.5. ENABLE/DISABLE INTERRUPT GENERATION

It is possible to enable/disable the Mod. V560 interrupt generation in the following way.

enable: by accessing the address Base + % 08 (Enable VME Interrupt);

disable: by accessing the address Base + % 0A (Disable VME Interrupt);

by accessing the address Base + % 50 (Clear Scales);

by pushing the front panel push-button "MAN CLR";

by generating the VME signal SYSRES.

5.6. INTERRUPT SEQUENCE

If the VME interrupt generation is enabled (access to the address Base + % 08):

{

- if the MSB of an enabled scale becomes true and the value of the interrupt level is different from 0:
 - {
 - it requests interrupt by driving an interrupt request line IRQ1..7 low according to the LEV<2..0> value;

 - during the following acknowledge cycle it places on the VME data lines D00..D07 the STATUS/ID; it is the byte contained in the 8 LSB of the Interrupt vector register (address Base +% 04);
 - }

- if a VME MASTER accesses (read or write) the address Base +% 0C (Clear VME interrupt) it releases its VME interrupt request line;

- if a VME MASTER accesses (read or write) the address Base +% 50 (Clear Scales):
 - {
 - it releases its VME interrupt request line;
 - it clears all the scales;
 - it disables the VME interrupt generation;
 - }

- }

6. REFERENCES

- [1] VMEbus Specification Manual Revision C.1 October 1985
- [2] G. Bianchetti et al., Specification for VMEbus CRATE Type V430, CERN-EP, January 1990.



CAEN S.p.A.

Via Vetraia 11
55049 - Viareggio
Italy
Phone +39 0584 388 398
Fax +39 0584 388 959
info@caen.it
www.caen.it

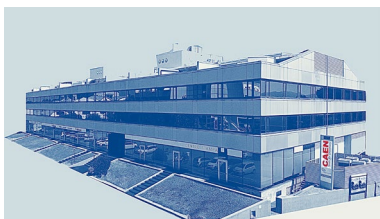

CAEN GmbH

Brunnenweg 9
64331 Weiterstadt
Germany
Tel. +49 (0)212 254 4077
Mobile +49 (0)151 16 548 484
info@caen-de.com
www.caen-de.com

CAEN Technologies, Inc.

1 Edgewater Street - Suite 101
Staten Island, NY 10305
USA
Phone: +1 (718) 981-0401
Fax: +1 (718) 556-9185
info@caentechnologies.com
www.caentechnologies.com

CAENspa INDIA Private Limited

B205, BLDG42, B Wing,
Azad Nagar Sangam CHS,
Mhada Layout, Azad Nagar, Andheri (W)
Mumbai, Mumbai City,
Maharashtra, India, 400053
info@caen-india.in
www.caen-india.in



Copyright © CAEN SpA. All rights reserved. Information in this publication supersedes all earlier versions. Specifications subject to change without notice.